

EXTREME FIRE

BIG 6 Firepit

Installation and Operating Instructions

MODEL NO. #50001 FLAT COLLAPSING PORTABLE FIREPIT

WARNING: If the information in these instructions is not followed exactly, a fire or explosion may result causing property damage, personal injury, or loss of life.

Do not store or use gasoline or other flammable vapors and liquids in the vicinity of this firepit when in use.

This appliance is designed only for burning wood, charcoal, and similar low-density materials. This appliance is not intended for use with coal or any high-density combustible materials.

This firepit can only be used on top of concrete pads, bare dirt areas, and grass covered areas. Do not use this appliance on top of any wood covered deck or walkway area. Doing so may cause the wood surface to catch on fire leading to property damage or personal injury.

This firepit can only be used outdoors in open areas.

Maintain a minimum of 10 feet, horizontally, between this firepit and any building structure or vehicle.

Do not attempt to transport this firepit while hot or when a fire is burning in it.

Hot Surfaces are Normal

Be aware that the surfaces of this firepit can be too hot to touch. This level of surface temperature is considered normal and does not indicate any hazardous situation. Use protective gloves when handling hot parts.

After each use, wait for the fire to burn out and cool completely before attempting to disassemble this firepit and package it in its transportation bag.

Table of Contents

1 General Information.....	2	1.4.1 Conditions.....	8
1.1 Safety Warnings.....	2	1.4.2 Exclusions.....	8
1.2 Parts Identification.....	3	1.4.3 Limitations of Liability.....	9
1.3 Assembly and Operating Instructions.....	4	1.4.4 How to Obtain Warranty Service.....	9
1.4 Warranty Policy Statement.....	8	1.5 Owner Registration.....	10

1 GENERAL INFORMATION

1.1 SAFETY WARNINGS

!WARNING!

The exhaust from this product contains chemicals to the State of California to cause cancer, birth defects or other reproductive harm.

Always keep the firepit clear and away from combustible materials, gasoline, and other flammable vapors and liquids during use.

Due to high temperatures, the firepit should be located out of traffic areas and away from plastic furniture.

Clothing or flammable material should not be placed on or near the firepit when in use.

Children and adults should be alerted to the hazards of high surface temperature and should stay away to avoid burns or clothing ignition.

Young children should be carefully supervised when they are in the vicinity of the firepits. Toddlers, young children, and others may be susceptible to accidental contact burns.

Do not use abrasive cleaners. Do not attempt to clean when it is hot.

Let the fire burn out and completely cool down before disassembling this firepit.

Do not place furniture or any other combustible household objects within 12" of the firepit when in use.

1.2 PARTS IDENTIFICATION

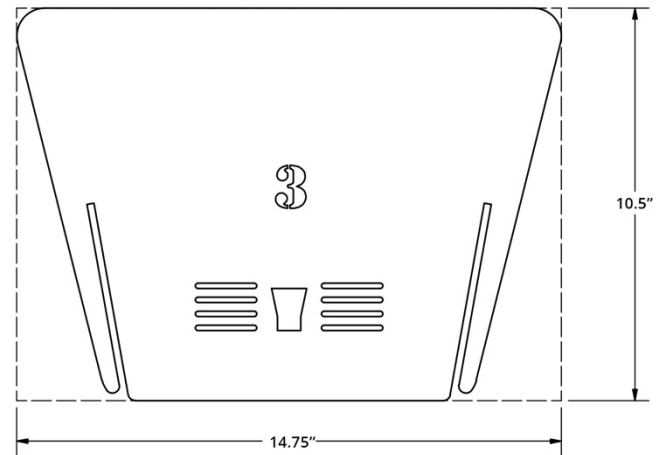
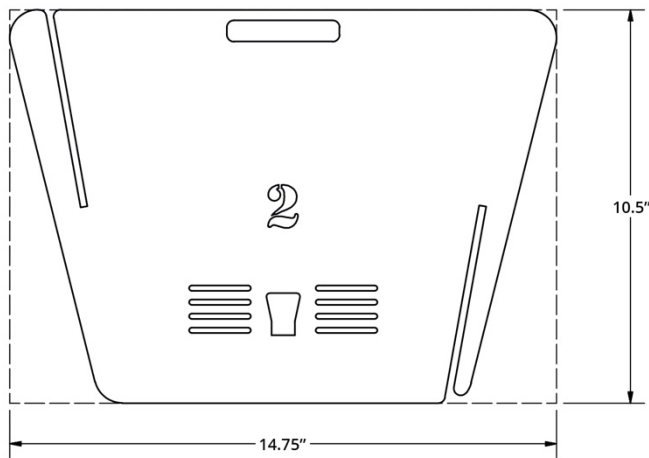
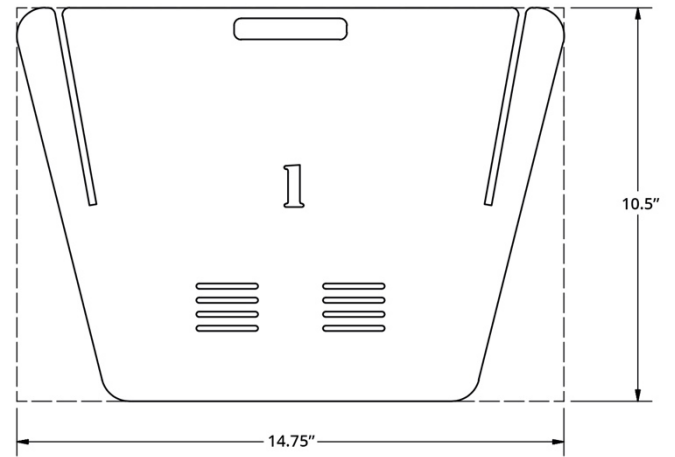
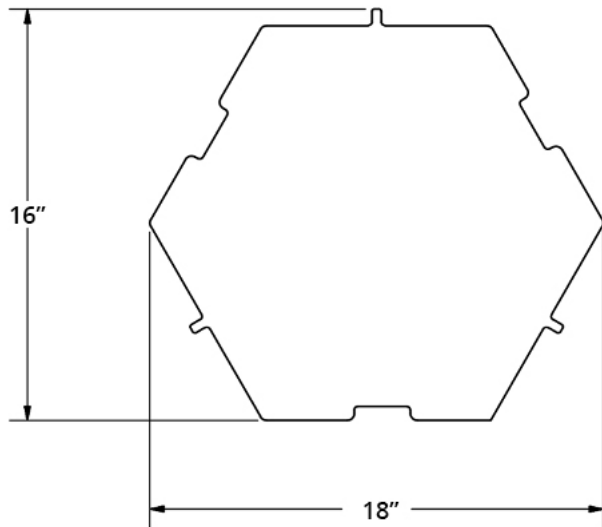

ITEM	QTY	PART NUMBER	DESCRIPTION
1	1	BA-03-00011	WALL #1, HEX FIREPIT
2	4	BA-03-00012	WALL #2, HEX FIREPIT
3	1	BA-03-00013	WALL #3, HEX FIREPIT
4	1	BA-03-00014	FLOOR, HEX FIREPIT

1.3 ASSEMBLY AND OPERATING INSTRUCTIONS

1. Top wall item #1 and bottom wall item #2 slide together.
2. Repeat for both #1 & #2 wall items

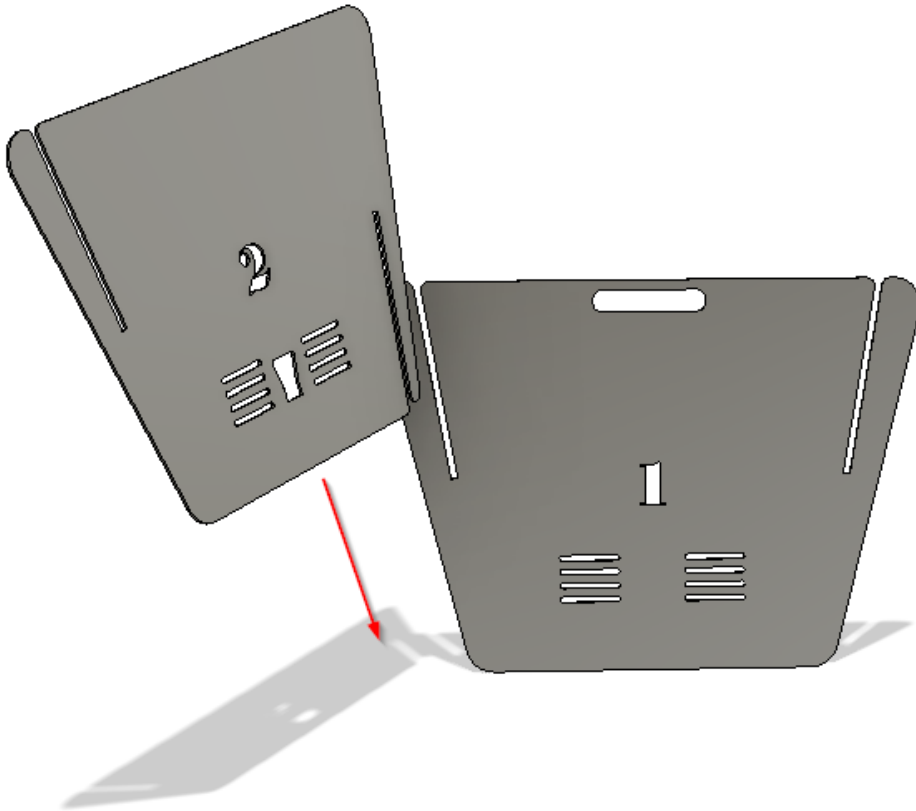

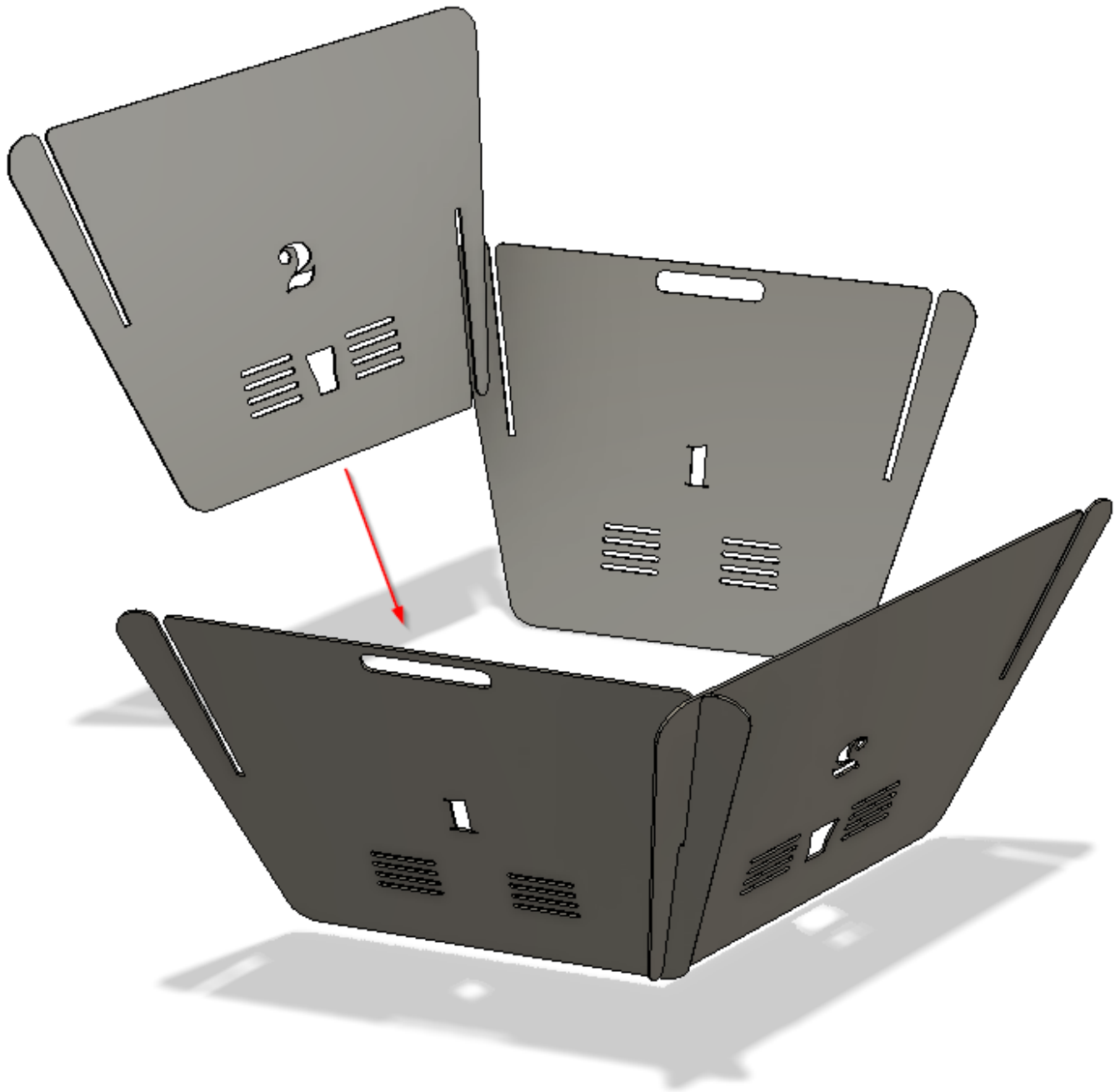

1. Connect the #1 & #2 wall groups with wall item #3.

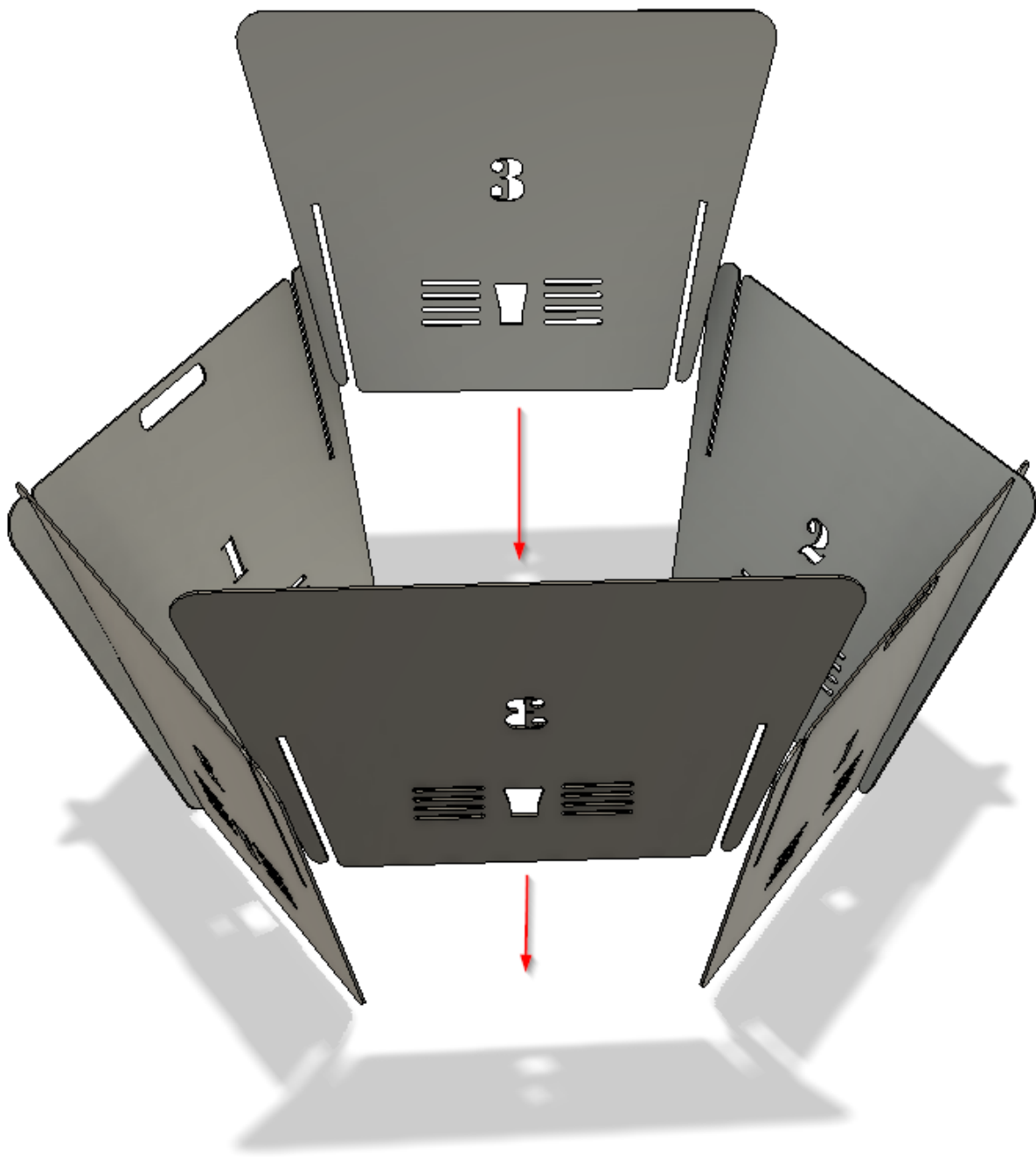

2. Gently insert the floor item, clipping into the walls.

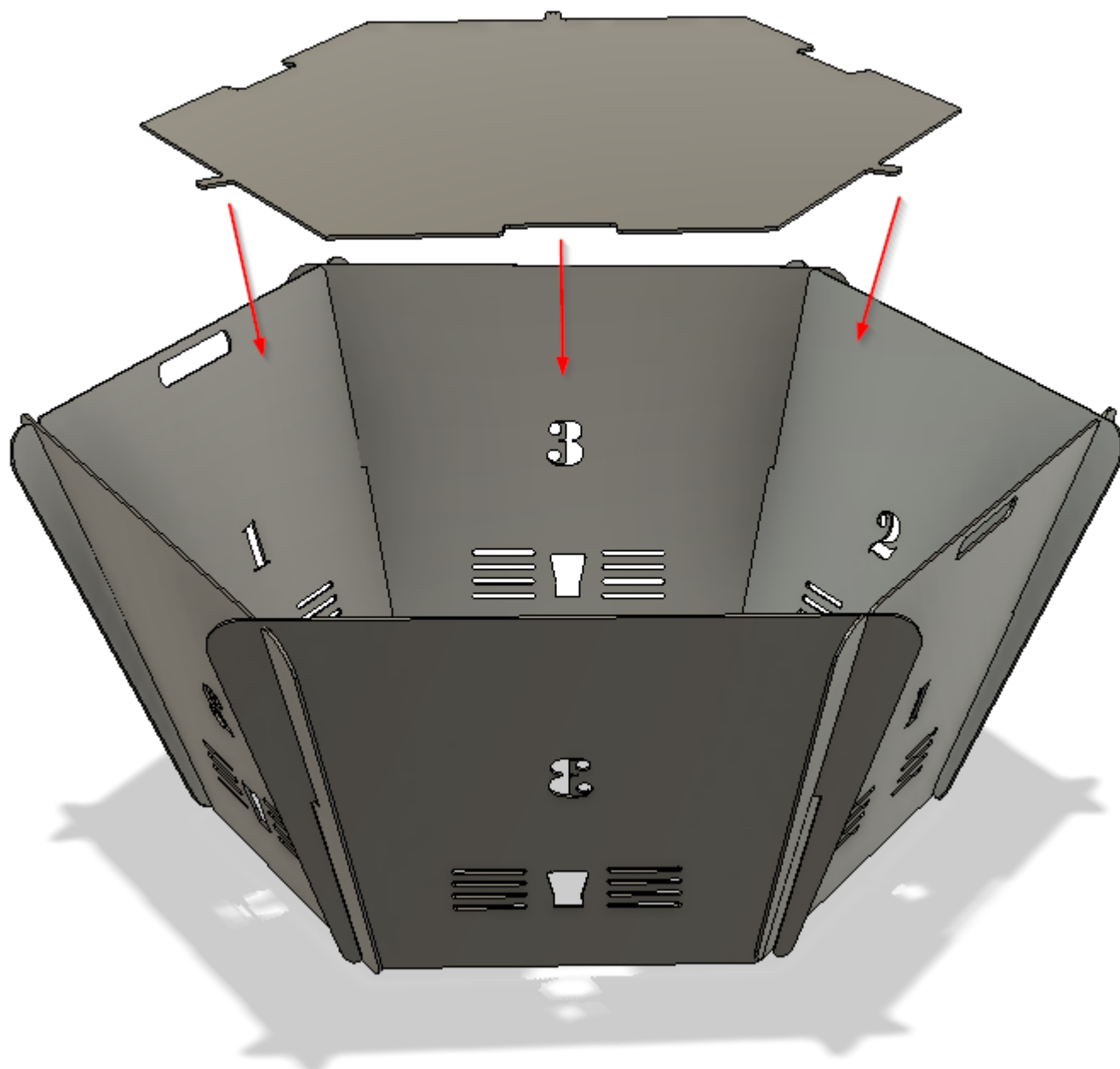

1.4 WARRANTY POLICY STATEMENT

Extreme Fire extends this Limited 1-Year Warranty to the original purchaser of this appliance provided the product remains in the original place of installation. The items covered by this Limited 1-Year Warranty and the period of such coverage is set forth in the table below.

The original purchaser can register for an extended 2-Year Warranty (one additional year). Please see section 1.5 for details on registration.

Some conditions apply (see below).

The policy is not transferable, amendable, or negotiable under any circumstances.

1.4.1 Conditions

Warranty protects against defect in manufacture or Extreme Fire assembled components only, unless herein specified otherwise.

Any part(s) found to be defective during the warranty period as outlined above will be repaired or replaced at Extreme Fire's option through an accredited distributor, dealer or pre-approved and assigned agent provided that the defective part is returned to the distributor, dealer or agent for inspection if requested by Extreme Fire. Alternatively, Extreme Fire may at its own discretion fully discharge all its obligations under the warranty by refunding the verified purchase price of the product to the original purchaser. The purchase price must be confirmed by the original Bill of Sale.

The authorized selling dealer, or an alternative authorized Extreme Fire dealer if pre-approved by Extreme Fire, is responsible for all in-field diagnosis and service work related to all warranty claims. Extreme Fire is not responsible for results or costs of workmanship of unauthorized Extreme Fire dealers or agents in the negligence of their service work.

At all times Extreme Fire reserves the right to inspect reported complaints on location in the field claimed to be defective prior to processing or authorizing of any claim. Failure to allow this upon request will void the warranty.

All warranty claims must be submitted by the dealer servicing the claim, including a copy of the Bill of Sale (proof of purchase by you). All claims must be complete and provide full details as requested by Extreme Fire to receive consideration for evaluation. Incomplete claims may be rejected.

Unit must be installed according to all manufacturers' instructions as per the manual.

All Local and National required codes must be met.

The original purchaser is responsible for cleaning and maintenance of the unit, as outlined in the owner's manual. As outlined below, the warranty may be voided due to problems caused by lack of cleaning or maintenance.

Repair/replacement parts purchased by the consumer from Extreme Fire after the original coverage has expired on the unit will carry a 90-day Warranty, valid with a receipt only. Any item shown to be defective will be repaired or replaced at our discretion. No labor coverage is included with these parts.

1.4.2 Exclusions

This Limited 1-Year Warranty does not extend to rust or corrosion of any kind due to a lack of maintenance or the presence of corrosive chemicals (i.e., chlorine, salt, air, etc.).

Malfunction, damage, or performance-based issues as a result of environmental conditions, location, chemical damages, operator error, abuse, misuse, use of improper fuels, lack of regular maintenance and upkeep, acts of God, weather related problems from hurricanes, tornados, earthquakes, floods, lightning strikes/bolts or acts of terrorism or war, which result in malfunction of the appliance are not covered under the terms of this Limited 1-Year Warranty.

Extreme Fire has no obligation to enhance or modify any unit once manufactured (i.e., as products evolve, field modifications or upgrades will not be performed on existing appliances).

This warranty does not cover dealer travel costs for diagnostic or service work. All labor rates paid to authorized dealers are subsidized, pre-determined rates. Dealers may charge homeowner for travel and additional time beyond their subsidy.

Any unit showing signs of neglect or misuse will not be covered under the terms of this warranty policy and may void this warranty. This includes units with rusted or corroded parts which have not been reported as rusted or corroded within three (3) months of purchase.

Units which show evidence of being operated while damaged, or with problems known to the purchaser and causing further damages will void this warranty.

Minor movement, expansion and contraction of the steel is normal and is not covered under the terms of this warranty.

Freight damages for products or parts are not covered under the terms of the warranty.

Products made or provided by other manufacturers and used in conjunction with the Extreme Fire appliance without prior authorization from Extreme Fire may void this warranty.

1.4.3 Limitations of Liability

The original purchaser's exclusive remedy under this warranty, and Extreme Fire's sole obligation under this warranty, express or implied, in contract or in tort, shall be limited to replacement, repair, or refund, as outlined above. IN NO EVENT WILL Extreme Fire BE LIABLE UNDER THIS WARRANTY FOR ANY INCIDENTAL OR CONSEQUENTIAL COMMERCIAL DAMAGES OR DAMAGES TO PROPERTY. TO THE EXTENT PERMITTED BY APPLICABLE LAW, Extreme Fire MAKES NO EXPRESS WARRANTIES OTHER THAN THE WARRANTY SPECIFIED HEREIN. THE DURATION OF ANY IMPLIED WARRANTY IS LIMITED TO DURATION OF THE EXPRESSED WARRANTY SPECIFIED ABOVE. IF IMPLIED WARRANTIES CANNOT BE DISCLAIMED, THEN SUCH WARRANTIES ARE LIMITED IN DURATION TO THE DURATION OF THIS WARRANTY.

Some U.S. states do not allow limitations on how long an implied warranty lasts or allow exclusion or limitation of incidental or consequential damages, so the above limitations or exclusions may not apply to you.

Customers located outside the U.S. should consult their local, provincial, or national legal codes for additional terms which may be applicable to this warranty.

1.4.4 How to Obtain Warranty Service

Customers should contact the authorized selling dealer to obtain Warranty service. In the event the authorized selling dealer is unable to provide Warranty service, please contact Extreme Fire by mail at the address listed below. Please include a brief description of the problem and your address, email, and telephone contact information. A representative will contact you to make arrangements for an inspection and/or Warranty service.

Warrantor:

Extreme Fire
3010 Spring Industrial Drive
Powder Spring, GA 30127
United States

1.5 OWNER REGISTRATION

All Extreme Fire products include a 1-Year Limited Warranty. Extreme Fire product owners should register to qualify for the extended 2-Year Limited Warranty.

Owners should complete the form available at:

ExtremeFire.com/Warranty

Note: Your Extreme Fire dealer can assist with Warranty applications and information.

Thank you for choosing Extreme Fire.